

F5

**EXPOSABLE
WALL MOUNTED
SENSOR URINAL
STAINLESS STEEL**

NEW



FEATURES



Touchfree Sensor Activated



Prevents Cross Contamination



Battery Operated



Low Power Consumption

TECHNICAL SPECIFICATIONS

EXPOSED URINAL SENSOR - BATTERY OPERATED - STAINLESS STEEL

Model	F5B	Function	Touchless Infrared Sensor
Material	Stainless Steel	Finish	Chrome
Mounting	Wall Mounting	Control Unit	All in One Unit
Sensor Range	300 to 350 Factory Set	Water Saver	NA
Control Box Mounting	NA	Power Source	6V DC 1.5V x 4 AA Battery
Water Inlet Size	0.5 inch BSP OD Thread	Water Pressure Range	0.7 Bar to 7 Bar (1 Bar optimum)
Port Orientation	90°	Battery Backup	Available

DIMENSIONS

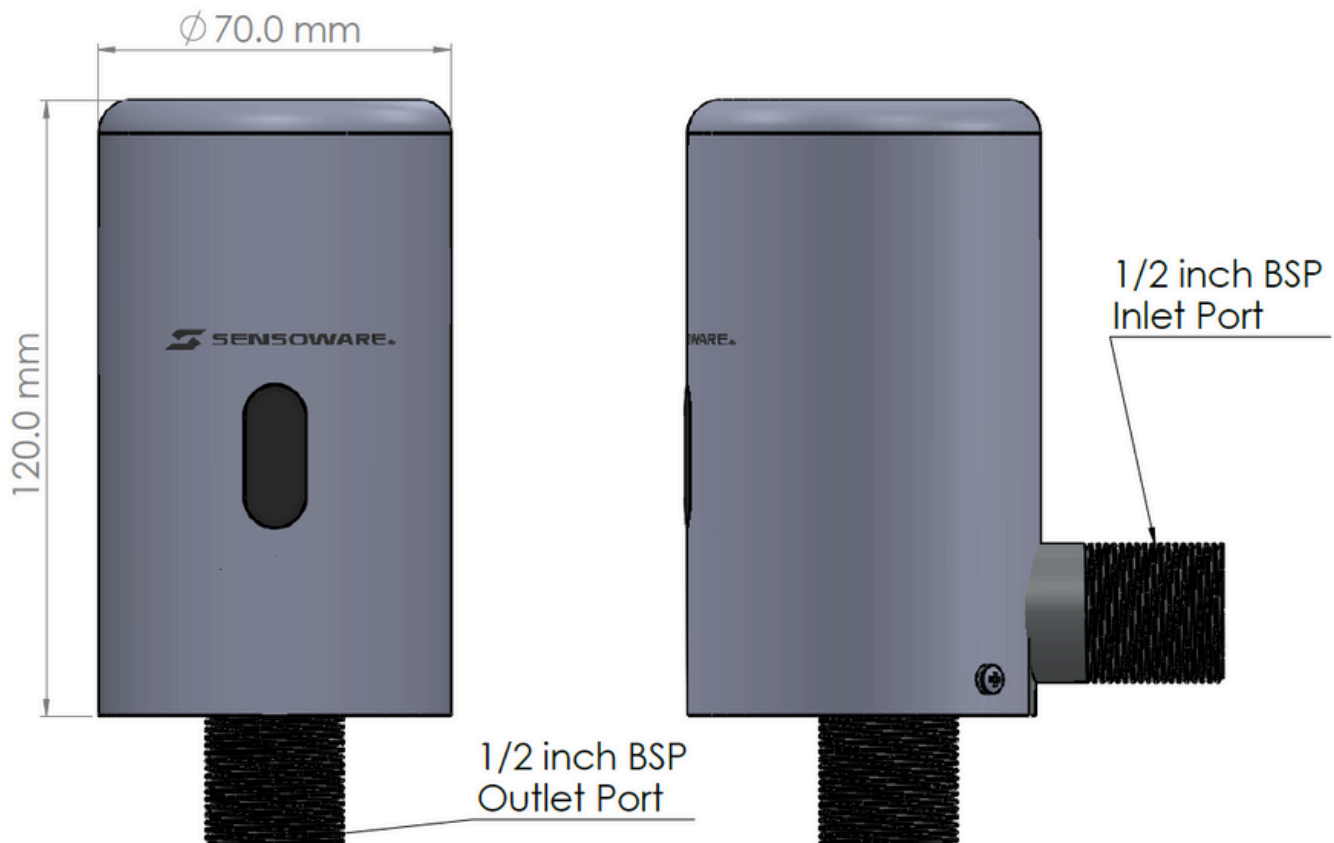

INSTALLATION LAYOUT



Exposable Urinal Sensor Unit

- Gently Screw the inlet port ½” BSP Male of the unit to your wall female fitting
- Use the Spanner slot given in the inlet port fitting. Don't hold the whole unit to tighten to the female wall threading.
- Use sealing Teflon tapes to seal the water leak in joints. Strictly don't use any adhesives.