

S5



NEW

SENSOR TAP FOR WASH BASINS

FEATURES



spout Sensor Operated



Prevents Cross Contamination



Water Saving Aerator



DC Adaptor Included



Battery Backup

TECHNICAL SPECIFICATIONS

WASH BASIN MOUNTED SENSOR TAPS			
Model	S5	Function	Touchless Infrared Sensor Spout Mounted
Material	Stainless Steel	Finish	Shinning Polished
Mounting	Wash Basin	Control Unit	Included
Sensor Range	40 to 100mm Self Adjusting	Water Saver	Foam Flow Erator
Control Box Mounting	Below the deck / Wash Basin	Power Source	6V DC Power Adaptor
Water Inlet Size	0.5 inch BSP OD Thread	Water Pressure Range	0.7 Bar to 7 Bar (1 Bar to Achieve Foam Flow)
Flow Rate	1 - 1.5 LPM	Battery Backup	Available

DIMENSIONS

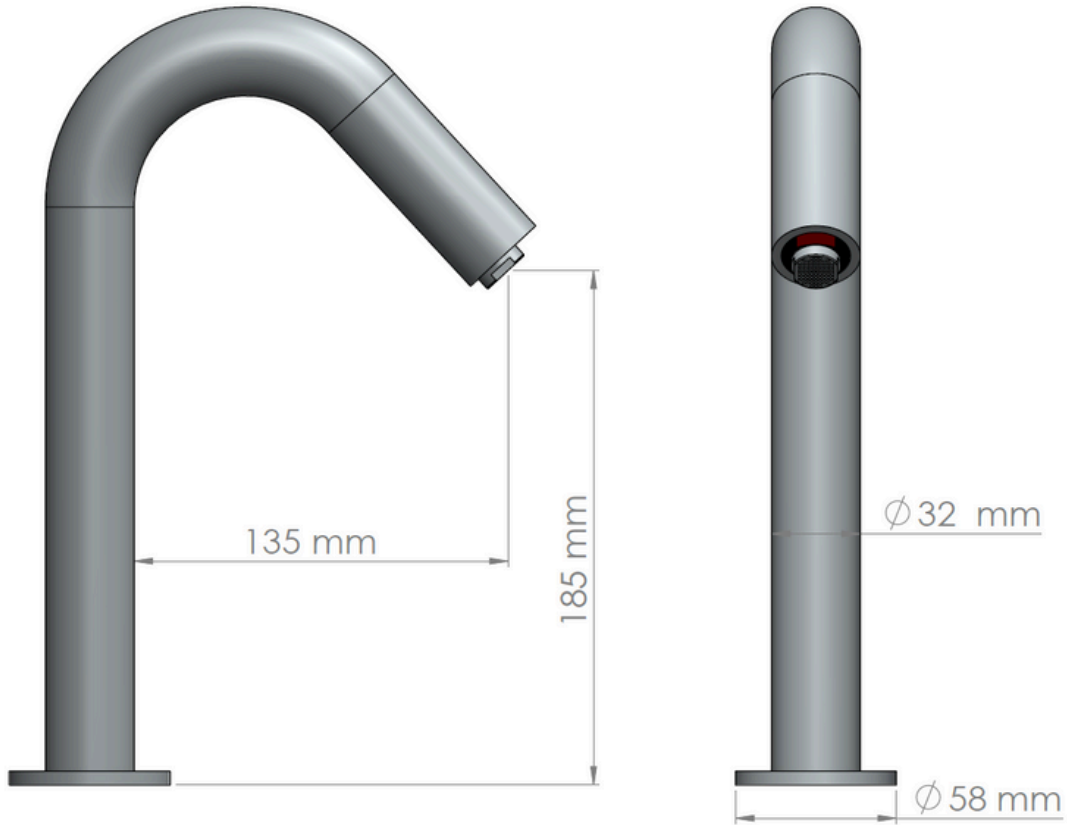

INSTALLATION LAYOUT

